

PANEL CUT OUT

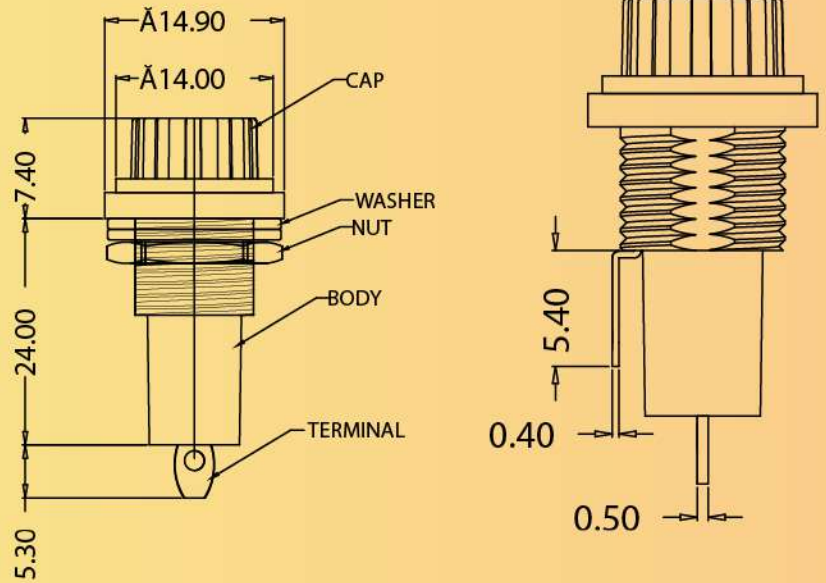

TECHNICAL SPECIFICATION

Note: All Dimension are in mm

PARAMETERS	SERIES	E-FH1 (Bakelite)
Mounting style		Panel
Permissible Temp.with/Without load		-20°C to +85°C
Permissible Temp. for Soldering		27°C for 5 seconds max.
Panel Thickness(Max.)		3mm max.
Material		BAKELITE
Insulation Resistance		1000 M Ohms min.
H.V. Break Down		2KV/AC For 1 Minite
Current Carrying Parts		Brass, Tin Plated
Contact Resistance(Initial)		10 m Ohms max.
Cap Design		Screw-In
App.Weight(gm)		5.5
Fuse Link Size		5x20 mm
Rated Current/Voltage		10 Amps/250V AC
Terminals		Solder type
Nut		Metal

Series Also Includes...

