

PRS 2 102 Twisting

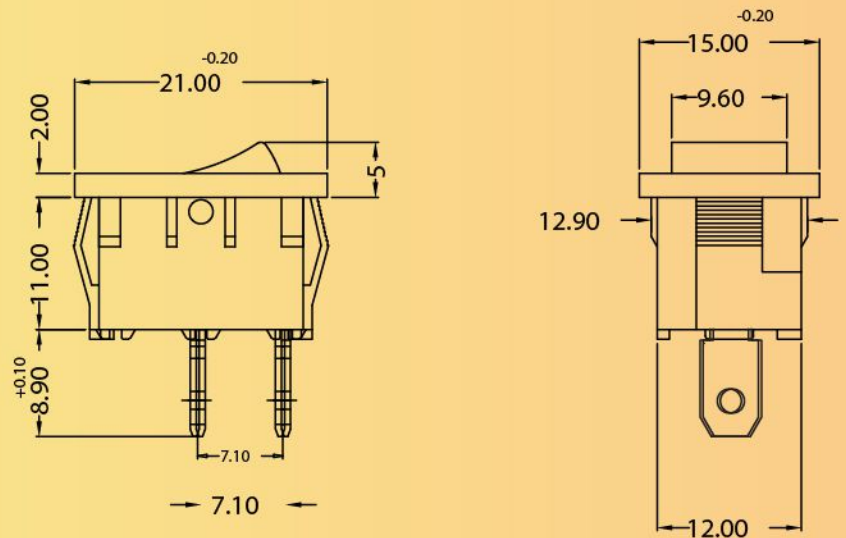

Circuit Diagram



PRS 2 102 Twisting

TECHNICAL SPECIFICATION

Note: All Dimension are in mm

PARAMETERS	SERIES	PRS 2-2A
Switch Type		Non-Illuminated
Model		SPDT/SPST
Current Rating		2A 250V AC
Insulation Resistance		> 100 M ohm min 500V DC
Dielectric Strength		> 1KV, 1 Minute
contact Resistance		10M Ohms mix.
Terminal Style		Fast On 4.8x0.80mm
Permissible Temp. for Soldering		270°, 5 sec. Max.
Moulded Material (Housing)		PA
Moulded Material (Rocker)		PA
Center Terminal		Brass (Tin plated)
Side Terminal		Brass(Tin plated)
Centre Contact		Brass(Dimple)
Fixing		Sanp Mounting
Electrical Endurance		5,000 Cycles
Sp. colour available on MOQ.		

Series Also Includes...



PRS 1



PRS 4



PRS 5



PRS 6



PRS 10



PRS 11



PRS 16



PRS 17 203



PRS 18 201